



Elegant armchair born to be a classic.

The studied dimensions and the subtle steel structure (available in two versions, fix or rocking), make NAGI a new icon in the VICCARBE collection.

Very comfortable thanks to its generously high back that supports the user's head and elegant arms that are perfect to rest on while reading or working.

TECHNICAL INFO

1. Internal structure of steel tubing covered with foam and rigid molded polyurethane.
2. Base calibrated steel lacquered polyester thermoreinforced.

FINISHES

Check upholstery samples

Base



white
RAL 9003



black
RAL 9005



altea blue
RAL 5000



fluorescent orange
RAL 2005

CERTIFICATES



NAGI design Tomoya Tabuchi 2015



NAGI - Rocking

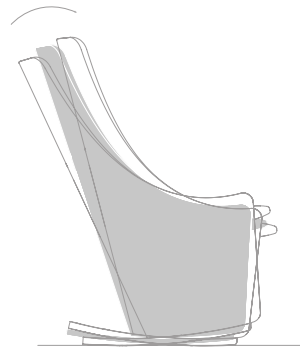
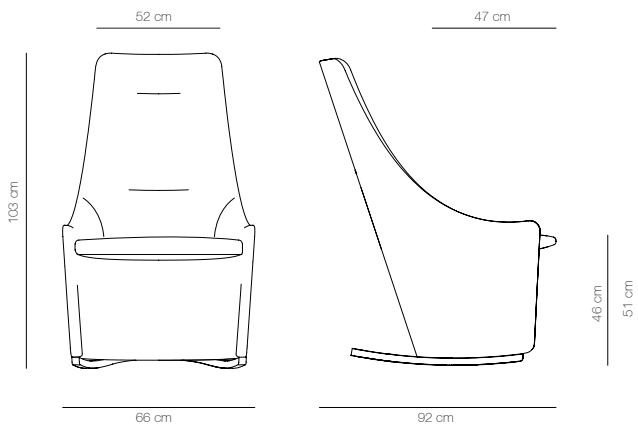

NAGI - Fix

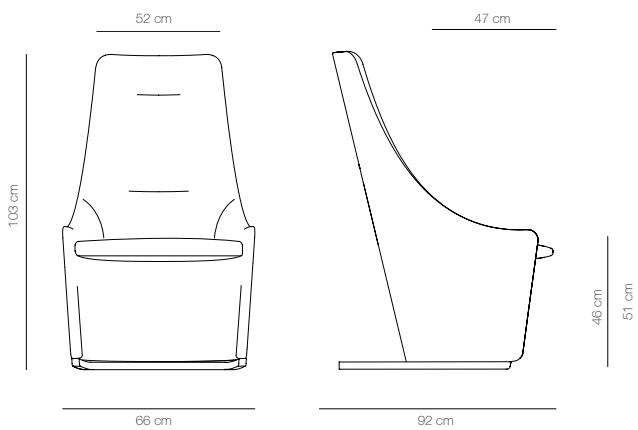

TOMOYA TABUCHIJapan



Tomoya Tabuchi, born in 1974, graduated in living design at Kuwasawa Design School in 1997.

After working at Japanese furniture firm on the planning, designing original products, developing products designed by overseas designers, he became independent in 2010.

In 2011, Tee table was debuted from INTERIORS(Japanese firm www.interiors-inc.jp) as his first design after independence.

His activity includes designed products, graphic design and art direction.

Awards.

2007 Premio Vico Magistretti , shortlist for prize

2012 ELLE DECOR Young Japanese Design Talent

2014 Good Design Award / Japanese Furniture Selection " TWIG "

PRODUCTUS

NAGI armchair