

ALETA by Jaime Hayon 2017



Inspired by the physiognomy and movement of sharks, Jaime Hayon has created the ALETA collection for Viccarbe.

The collection is designed and created for use in public spaces like restaurants, hotels or offices as well as residential spaces.

Composed of a chair and stool. The subtle details in the structure of the legs and the continuous movement towards its backrest, reflects the personality and character of Jaime Hayon.

## JAIME HAYON



Spanish artist-designer Jaime Hayon was born in Madrid in 1974. After studying industrial design in Madrid and Paris he joined Fabrica – the Benetton-funded design and communication academy in Italy- in 1997 where he directed the design department until 2003. Hayon set up his own studio practice in the year 2000 and dedicated himself fully to his personal projects from 2003 onward, today he is one of the most acclaimed creators worldwide.

He has created furniture ranges for iconic danish company Fritz Hansen, Magis, Established and Sons, Bisazza, B.D. Barcelona, Se London, Bernhardt Design, Ceccotti and

Moooi. Hayon has designed various lighting fixtures collections for Metalarte and also in collaboration with Swarovski and Baccarat. He has created accessories for Piper Heidsieck, Gaia and Gino and The Rug Company. He designed his first wristwatch collection for a new Swiss watch brand OROLOG which launched in late 2013. These collections have put Jaime at the forefront a new wave of creators that blurred the lines between art, decoration and design and a renaissance in finely-crafted, intricate objects within the context of contemporary design culture.

With offices in Italy, Spain and Japan, Hayon's main interest is to find challenges and new perspectives continuously.

DIMENSIONS

ALSIME metallic base chair

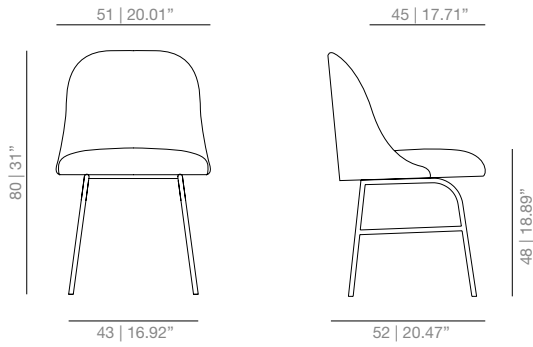

ALSIMEB metallic base low chair

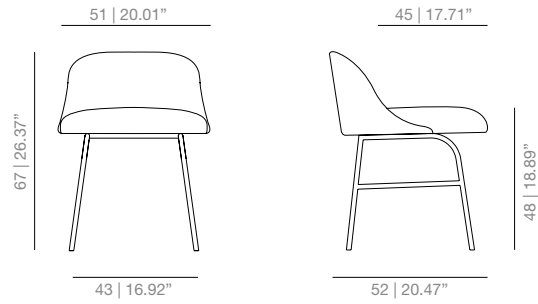

ALSIMA wooden base chair

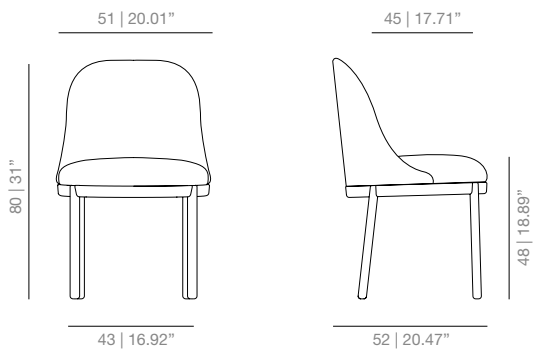

ALIMAB wooden base low chair

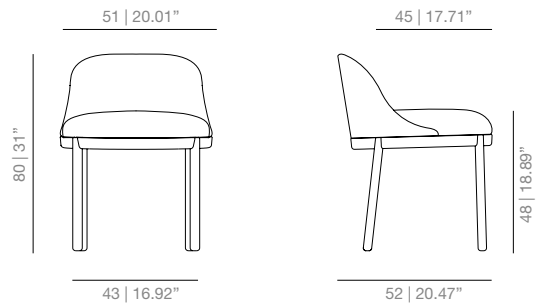

ALTAA stool

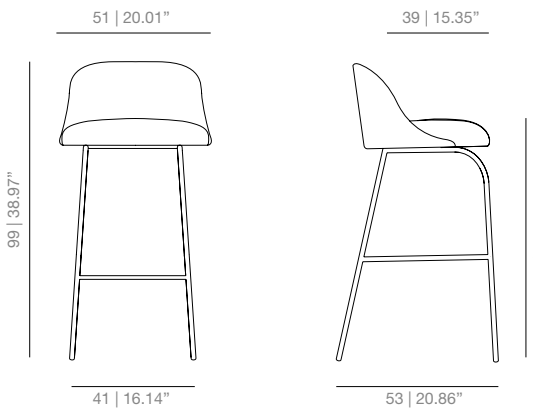

ALTAB high stool

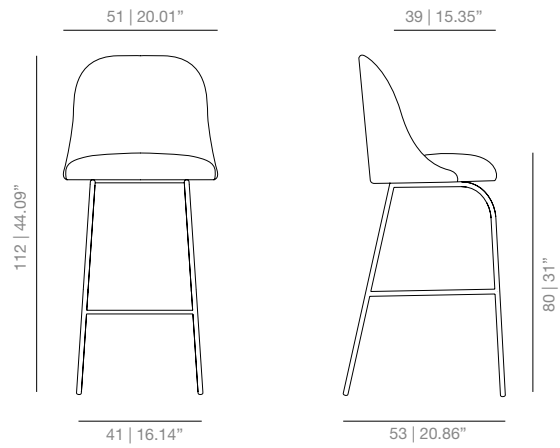

ALTAB low stool

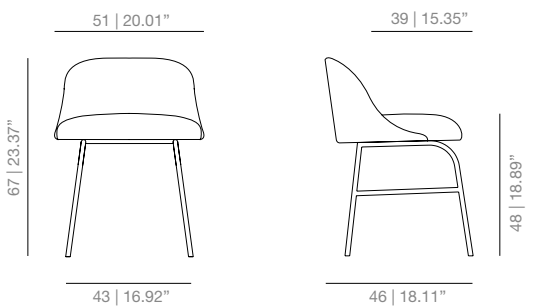

**TECHNICAL INFO**

Molded shell in 3D surface veneer.

Structure in gauged lacquered steel tube in thermoreinforced polyester, in black, white, fluorescent orange and raw steel finish (protected with a transparent lacquer).

Non stackable

**FINISHES**

Unpholstery

Check upholstery samples

Structure



white  
RAL 9003



black  
RAL 9005



altea blue  
RAL 5000



sand  
NCS 3005Y50R



matt  
oak



wenge



cognac



ash



## PROJECTS

Princess Nora Bint Abdulrahman University | The Bank of Nova Scotia | Government of the province of British Columbia | Bank of America Corporation | AC Hotels | Chicago University | Michigan State University | American Express | Bancaja | Banco del Caribe | Confortel Hotels | Eli Lilly & Co | Grand Hyatt Hotel | Hyatt Hotel | Marroyo Hotel | Radison Hotel | Simplot Headquarters | Telus Corporation | Robert Mills | PBS | Parkhouse | Veuve Clicquot Milano | P.R. House | Meliá Hotel Valencia | E+J Residence | Duravit | Airport Zaragoza | 33rd America's Cup | E.R. House | FIM Valencia | University of Utah | NBC Universal New York | New Balance Massachusetts | Bank of Nova Scotia | Dell Texas | Institute of Peace | Michigan Library and Historica | Manulife Financial | The Prudential Insurance | Auditorio y Palacio de Congresos de Castellón