

Molteni & C

PANNA COTTA— RON GILAD 2012

1—
2



Panna Cotta low table oval or round. At once delicate and heavy, the paradox lies in the use of materials such as marble and iron to achieve a fragile stability. Base and top made of black, white or red lacquered metal, combined with tone-on-tone White Carrara, Grey Carnian or Red French marbles.

FEATURES

Thin structured table top in stabilised steel wire with a marble counterweight. The table top presents a slight vibration due to the elasticity of the structure.

DATASHEET

REGISTERED
DESIGN

XII.2014

molteni.it

Dimensions in millimeters and inches. The right to discontinue and make changes is reserved. This information is based on the latest product information available at the time of printing.

FINISHES

matt white lacquer with white Carrara marble
matt black lacquer with carnian grey marble
matt red lacquer with red French marble (only for small round table)

Molteni & C

TECHNICAL INFORMATION

STRUCTURE

Welded drawn steel painted in the colours of the range. Nylon foot.

TOP

Steel sheet painted in the colours of the range.

COUNTERWEIGHT

Marble in the finishes of the range.

2—
2

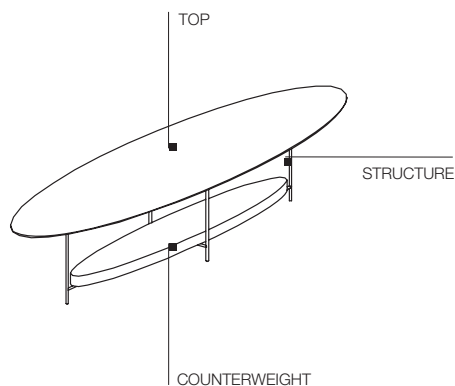
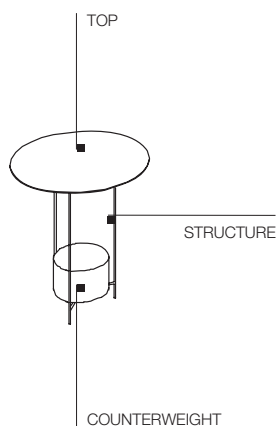

DIMENSIONS

small round table

Ø 400 H 500
Ø 15 3/4" H 19 5/8"

oval small table

W 1800 D 500 H 350
W 70 7/8" D 19 5/8" H 13 3/4"



GPT1

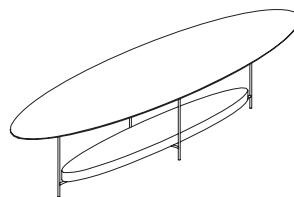

GPT2

DATASHEET

REGISTERED
DESIGN

XII.2014