

38 is a surrealistically motivated re-exploration of a technique originally developed for a previous project called 28, whereby air is pushed in and out of glass that is intermittently heated and cooled. In the case of this project, the technique is stretched to the limits of possibility. Large glass spheres are blown, and then a multitude of white cavities are introduced into them haphazardly, intentionally intersecting and colliding with each other. Several of these are deep enough to contain earth and succulent and cacti plantings. Others are used as housings for lighting elements. There are two or three lighting elements per large sphere, and one or two planters. Electricity and suspension are achieved using stiff copper tubing, which is allowed to tangle and crinkle, seemingly without regard for gravity. Once in a while, these copper tubes loop around moon white planters, appearing to have escaped from the confines of the lit clear glass spheres.

MATERIALS

Blown glass, copper tubing, electrical components and a white powder coated canopy.

- Air plants, succulents and cacti (not included) require least amount of care. Customer can consult a professional about the appropriateness of other plants.
- When watering the plants, please wait for the glass to cool down.
- As an alternative to a built-in transformer, Bocci recommends mounting transformers remotely in an easily accessible and hidden location for ease of long-term maintenance.
- The installation of the 38 is more involved than other chandeliers due to the manipulation and composition of the copper tubing.
- These standard chandeliers can be used in an infinite variety of groupings to create cohesive installations, with single pendants bridging from canopy to canopy.

Purchase replacement lamps online at www.bocci.ca/lamps

Unless otherwise noted when ordering, all chandeliers will include xenon lamps.

Worldwide patents issued and pending
Made in Vancouver, Canada

For additional information, please contact:

BOCCI Vancouver

info@bocci.ca

www.bocci.ca

BOCCI Berlin

infoeu@bocci.ca

www.bocci.ca

approx. 75kg (165lb)

RECTANGLE

38.28

Design by Omer Arbel
PRODUCT SPECIFICATION

© 2010, Bocci Design and Manufacturing Inc. All rights reserved. These drawings and the information contained herein may not be reproduced, communicated to the public, or made available in whole or in part without prior permission. Any inquiries should be directed to the following email address: admin@bocci.ca.

BOCCI

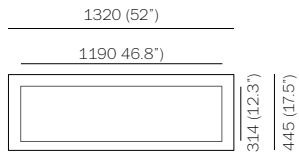

1

Measure and mark out the chandelier canopy position on the ceiling.

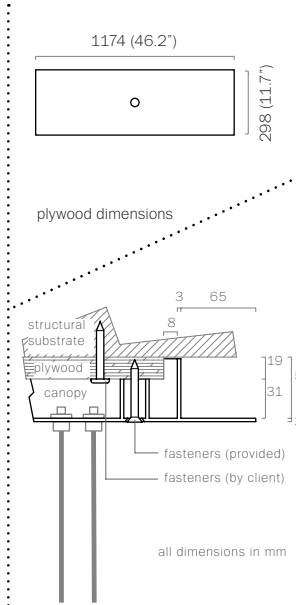

2

Note: The client is responsible for providing a robust 3/4" (19mm) plywood backing or wood blocking to securely anchor to the structural substrate.

Connections from the plywood to the structural substrate are the client's responsibility. Measure the plywood so that it fits within the canopy side walls. (refer to detail above).

Anchor the plywood backing to the structural ceiling substrate.

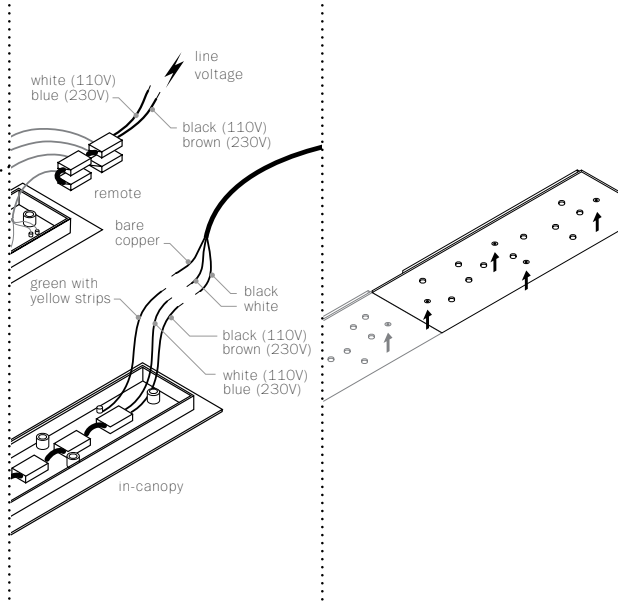

3

Connect transformers inside the canopy to line voltage. 110 V or 230 V depending on transformer.

For 110 V, connect black wire to the black wire and white wire to the white wire.

For 230 V, connect black wire to the brown wire and white wire to the blue wire.

For the ground connection, connect the green wire with yellow stripe to the bare copper wire or green wire in the junction box.

Note: As an option, Bocci recommends mounting transformers remotely in a close, accessible and hidden location for ease of long term maintenance. Installation to be done by certified personnel to insure code compliance.

4

Anchor canopy into the plywood backing using the fasteners provided.

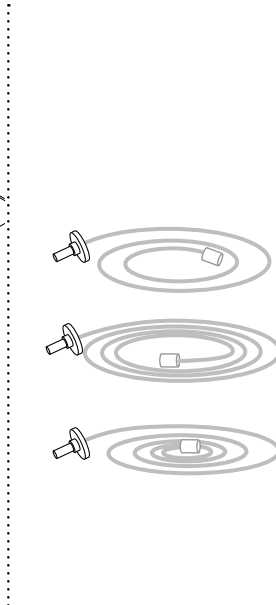

5

Separate the copper tubes according to length.

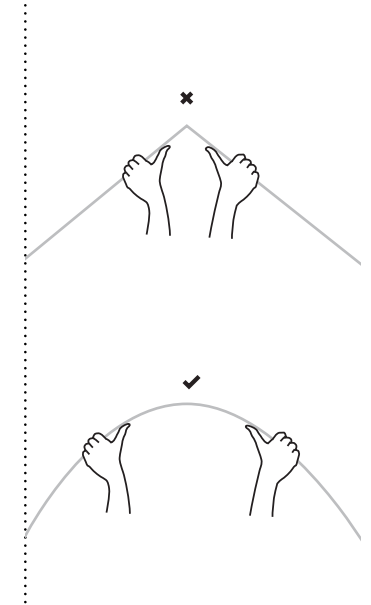

6

Very carefully uncoil the copper tube with both hands to avoid kinking.

Note: be very careful not to overbend the copper tubes as it will leave a permanent kink that can not be removed.

RECTANGLE

38.28

Design by Omer Arbel
INSTALLATION INSTRUCTIONS

© 2010, Bocci Design and Manufacturing Inc. All rights reserved. These drawings and the information contained herein may not be reproduced, communicated to the public, or made available in whole or in part without prior permission. Any inquiries should be directed to the following email address: admin@bocci.ca.

BOCCI

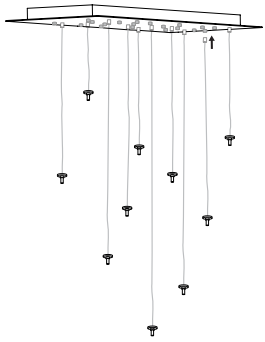

7

Install the marked shorter copper tubes for hanging the pendants. Space the tubes so the pendants will not touch one another when installed.

Each pendant terminates in a headphone jack type connector, which plugs into a receiving receptacle in the canopy.

Plug in each headphone jack connector and turn the threaded barrels into place ensuring it is adequately tightened.

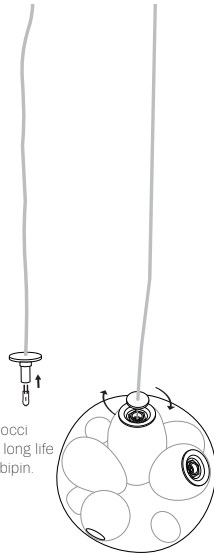

10W Bocci
24.1.1 long life
xenon bipin.

8

Bocci 24.1.2 long life bipin xenon lamps are included. Plug a lamp into each socket prior to connecting to the pendant. Do not touch the lamp with you bare hands.

Determine the placement of each pendant by choosing the topmost mounting point that will allow the large cavities to face upwards in order to receive the plants.

Connect each pendant to one tube by tightening the center cap by hand. Do not over tighten.

Note: When using a dimmer, use low voltage electronic dimmer.

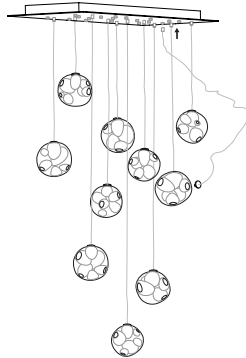

9

Install the remaining tubes to the canopy one at a time, gently bending them with both hands to avoid kinking.

The composition of the chandelier is determined by which tubes are chosen to connect to the remaining pendant mounting points.

In most configurations the longer tubes will coordinate with the longer pendants.

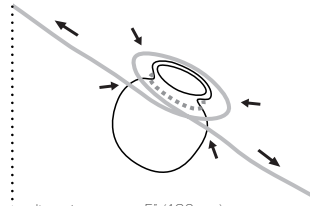

diameter approx. 5" (130mm)

10

Prior to connecting the remaining tubes to the pendants, be sure to install the glass moons, one moon per tube.

When installing the moons, first gently form a loop with the tube approximately 5" (130 mm) in diameter in the location of your choice. Insert the moon into the loop and tighten the loop around the moon, using the glass lip as a guide.



11

Once the moons are installed, install lamps before connecting the tubes to the pendants.

Connect the tubes to the pendants by tightening the center cap by hand. Shape the tubes in any direction to create a composition to your liking, taking care to fill gaps and create an appearance of weightlessness.

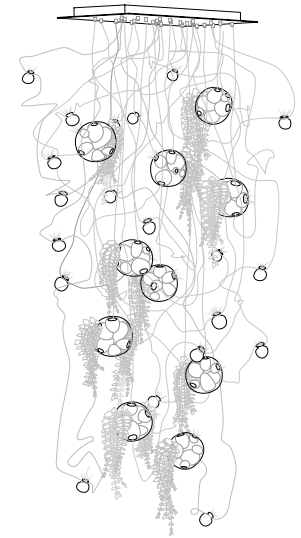

12

Place the plants into the pendant and moon cavities as desired. Reshape the tubes as needed.

Note: Bocci recommends succulents and/or air plants (plants not included).

Turn chandelier on.

*

Purchase replacement lamps online at www.bocci.ca/lamps

For additional assistance, please contact Bocci:

BOCCI Vancouver
info@bocci.ca
www.bocci.ca

BOCCI Berlin
infoeu@bocci.ca
www.bocci.ca

Made in Canada

RECTANGLE

38.28

Design by Omer Arbel
INSTALLATION INSTRUCTIONS

© 2010, Bocci Design and Manufacturing Inc. All rights reserved. These drawings and the information contained herein may not be reproduced, communicated to the public, or made available in whole or in part without prior permission. Any inquiries should be directed to the following email address: admin@bocci.ca.

BOCCI